

DE	<b>Schütz</b> Originalbetriebsanleitung	CS	<b>Stykač</b> Originální návod k obsluze	HU	<b>Mágnescapcsoló</b> Eredeti üzemeltetési útmutató
EN	<b>Contacteur</b> Original Operating Instructions	HR	<b>Sklopnik</b> Originalne upute za uporabu	PL	<b>Stycznik</b> Oryginalna instrukcja obsługi
FR	<b>Contacteur</b> Instructions de service originales				

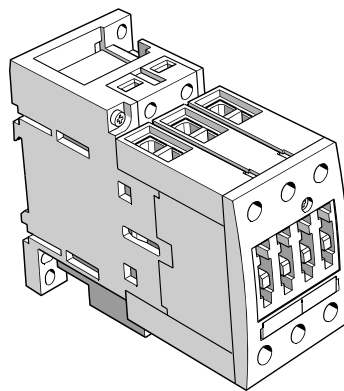

DE		 <b>GEFAHR</b>	<b>Gefährliche Spannung. Lebensgefahr oder schwere Verletzungsgefahr.</b> Vor Beginn der Arbeiten Anlage und Gerät spannungsfrei schalten. Die Installations- und Wartungsarbeiten an diesem Gerät dürfen nur von einer autorisierten Elektrofachkraft ausgeführt werden.
EN		 <b>DANGER</b>	<b>Hazardous voltage. Will cause death or serious injury.</b> Turn off and lock out all power supplying this device before working on this device. Installation and maintenance work on this device may only be carried out by an authorized electrician.
FR		 <b>DANGER</b>	<b>Tension dangereuse. Danger de mort ou risque de blessures graves.</b> Mettre hors tension avant d'intervenir sur l'appareil. Les travaux d'installation et d'entretien de cet appareil doivent uniquement être réalisés par une personne qualifiée en électricité.
CS		 <b>NEBEZPEČÍ</b>	<b>Nebezpečné napětí. Nebezpečí smrtelného nebo těžkého úrazu.</b> Před zahájením prací odpojte zařízení a modul od napětí. Instalační a údržbářské práce smí na tomto přístroji provádět pouze kvalifikovaný elektrikář.
HR		 <b>OPASNOST</b>	<b>Opasni napon. Opasnost po život ili opasnost od teških ozljeda.</b> Prije početka radova isključite napajanje postrojenja i uređaja. Radove instalacije i održavanja na uređaju smije izvoditi samo ovlašteno stručno elektrotehničko osoblje.
HU		 <b>VESZÉLY</b>	<b>Veszélyes feszültség. Életveszély vagy súlyos sérülésveszély.</b> A munkák megkezdése előtt végezze el a berendezés vagy készülék feszültség-mentesítését. Ezen az eszközön a telepítéssel és a karbantartással kapcsolatos feladatokat kizárólag megfelelő felhatalmazással rendelkező villamossági szakember végezheti.
PL		 <b>NIEBEZPIECZEŃSTWO</b>	<b>Niebezpieczne napięcie. Zagrożenie życia lub niebezpieczeństwo ciężkich obrażeń.</b> Przed rozpoczęciem wszelkich prac należy urządzenie i przyrząd odłączyć od sieci elektrycznej. Prace instalacyjne i konserwacyjne na tym urządzeniu może przeprowadzać wyłącznie posiadający odpowiednie kwalifikacje elektryk.



LSD2....

<b>Zentrale / Headquarters:</b>	PHONE: +43(0)1/866 85-0
SCHRACK TECHNIK GMBH	FAX: +43(0)1/866 85-1520
Seybelgasse 13	E-mail: <a href="mailto:export@schrack.com">export@schrack.com</a>
A-1230 Vienna	Internet: <a href="http://www.schrack.com">www.schrack.com</a>

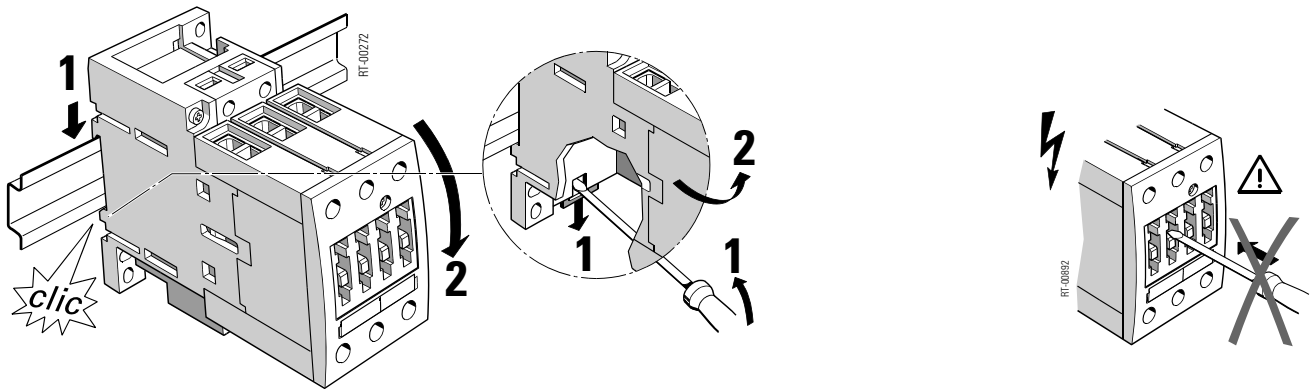

LSZ0D...

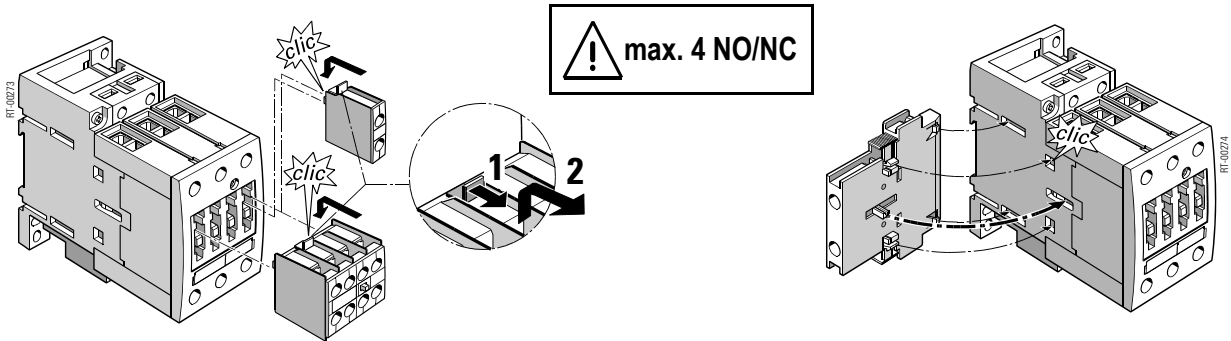

! max. 4 NO/NC

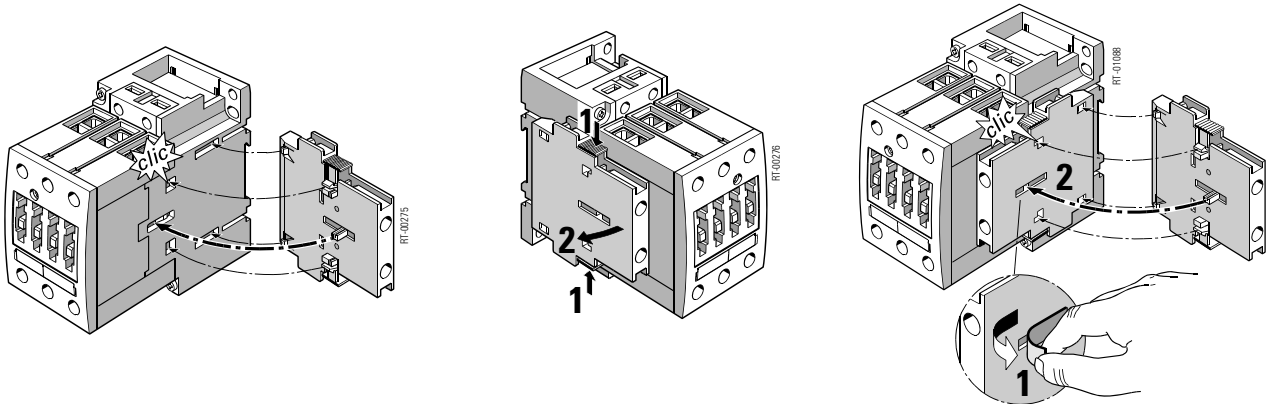



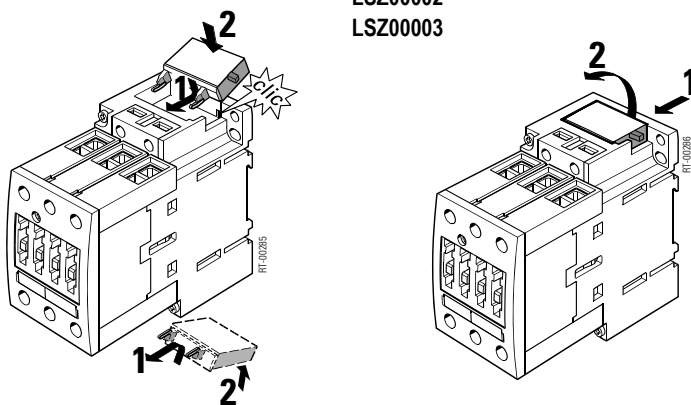

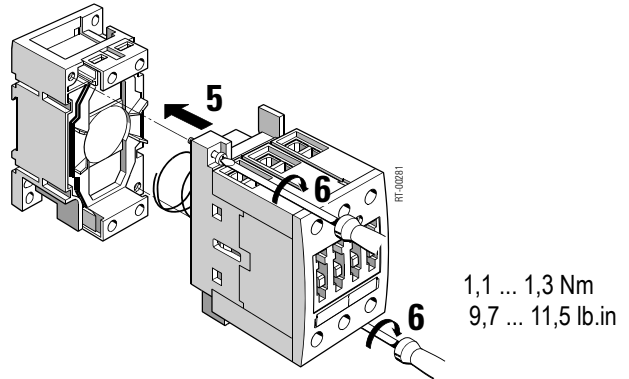
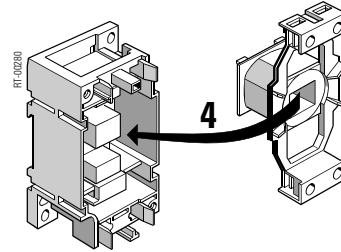
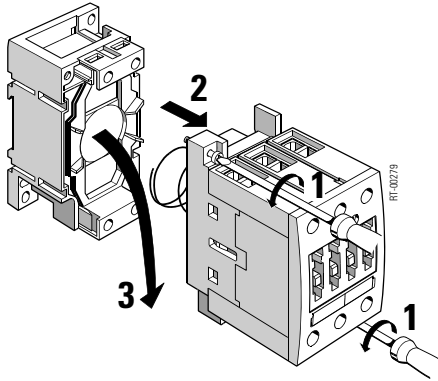
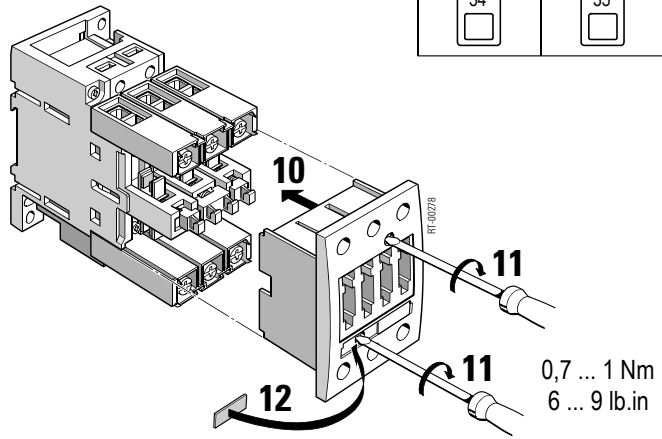
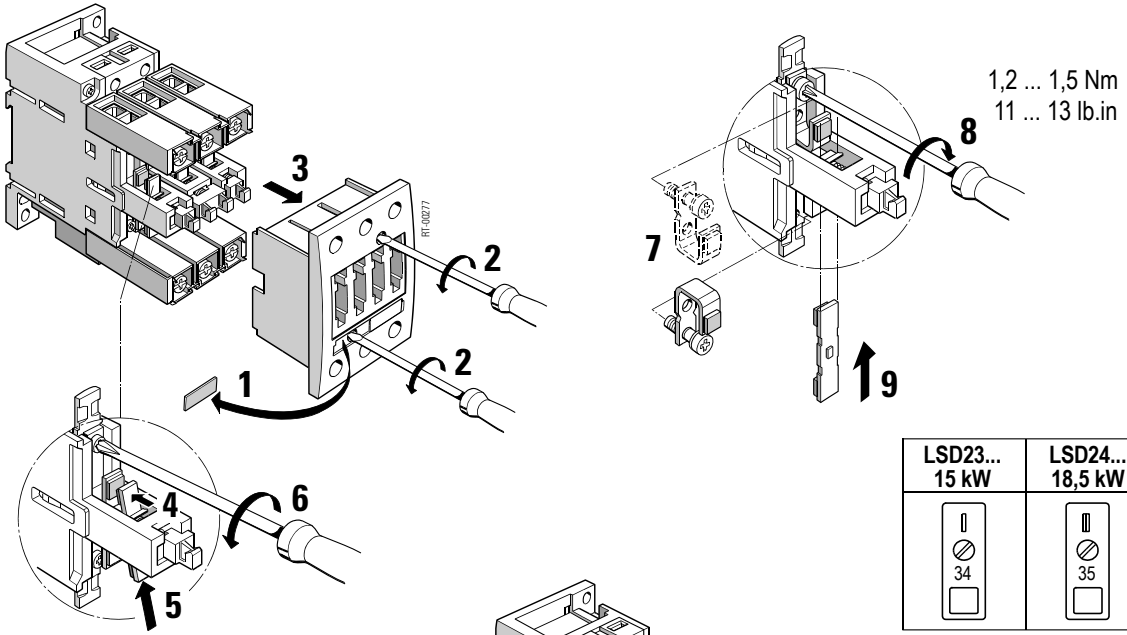

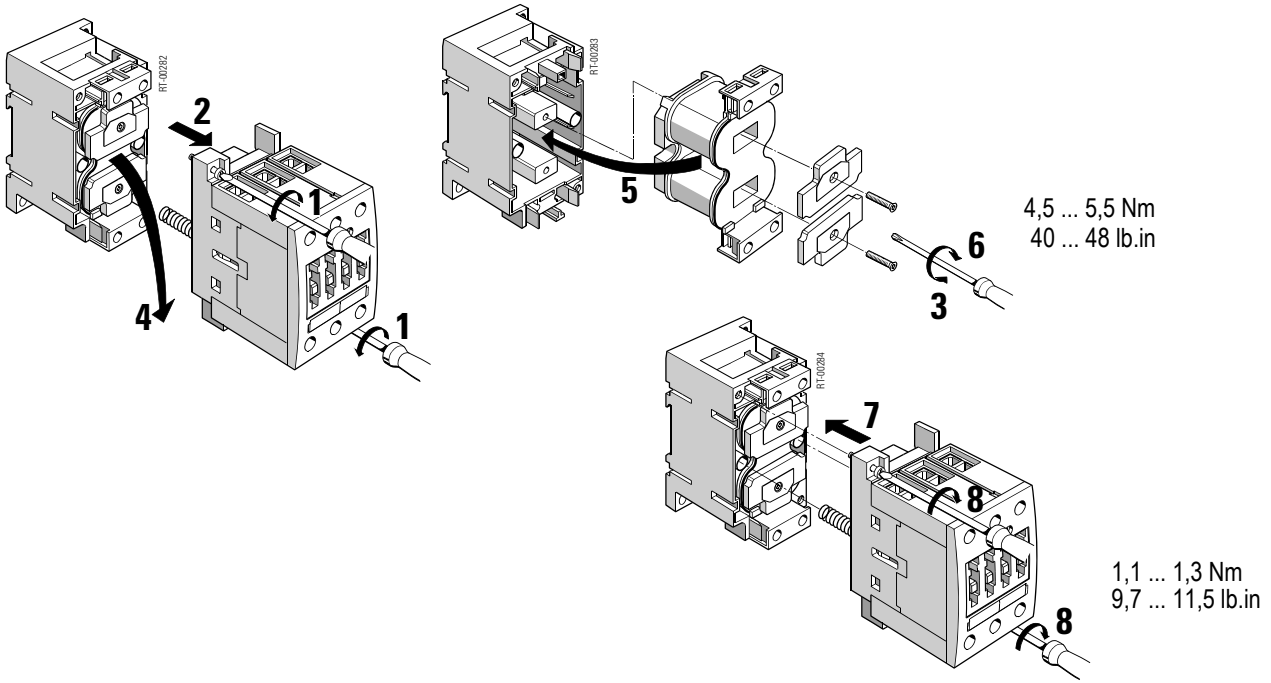

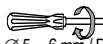
LSZ20001  
LSZ00001  
LSZ00002  
LSZ00003







	A1/A2; NO/NC LSZ0D...	L1 L2 L3 T1 T2 T3
	✳	✳
	 0,8 ... 1,2 Nm 7 to 10.3 lb.in Ø 5 ... 6 mm / PZ2	 3 ... 4,5 Nm 27 to 40 lb.in Ø 5 ... 6 mm / PZ2
	2 x 0,5 ... 1,5 mm <sup>2</sup> 2 x 0,75 ... 2,5 mm <sup>2</sup>	 2 x 0,75 ... 16 mm <sup>2</sup>
	2 x 0,5 ... 2,5 mm <sup>2</sup>	 2 x 0,75 ... 16 mm <sup>2</sup> 1 x 0,75 ... 25 mm <sup>2</sup>
	—	 2 x 0,75 ... 25 mm <sup>2</sup> 1 x 0,75 ... 35 mm <sup>2</sup>
<b>AWG</b>	2 x 18 to 14	<b>AWG</b> 2 x 18 to 3 1 x 18 to 2

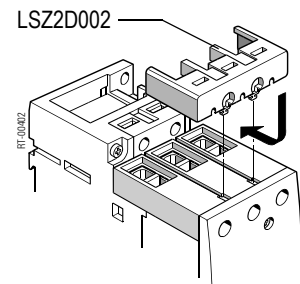

LSD2....

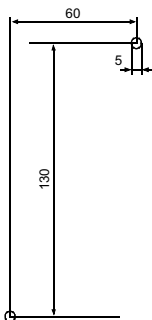
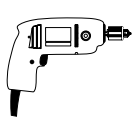

mm

